

**terneo sn** thermostat is designed for organizing snow and ice melting systems that ensure the safety of movement of people and vehicles, as well as reduce the rate of damage during the winter period. The temperature is controlled in the place where the temperature sensor is located.

According to data from the temperature sensor, the thermostat turns on the heat when the air temperature reaches a set range.

**IN THE BOX**

Thermostat	1 piece
Temperature sensor with connected sensor	1 piece
Technical data sheet and installation and operation manual and warranty card	1 piece
The packing box	1 piece

**TECHNICAL DATA**

The limits of regulation	upper: 0...10 °C lower: -20...-1 °C
Rated load current	32 A (max 40 A in 10 minutes)
Rated load capacity	7 000 VA
Input voltage	230 V ±10 %
Weight in the complete set	0,285 kg ±10 %
Overall dimensions	53 × 85 × 66 mm
Temperature sensor	NTC thermo-resistor 10 kOhm 25 °C (R10)
The length of the sensor connected cable	4 m
Number combinations under heat, at least	100 000 cycles
Number of combinations without heating, no less than	1 000 000 cycles
Degree of protection GOST14254	IP20
Measured temperature range	-30...+85 °C
Power consumption	no more than 1,5 kW*h/m

**IMPORTANT.** Before the installation and operation of the device, please read by the end of this document. This will help to avoid possible danger, mistakes and misunderstandings.

**WIRING**

The thermostat supports analog (R10, default) or digital (D18) sensor.

The temperature sensor is connected to terminals 1 and 2. To connect a digital sensor:

- connect the blue wire to terminal 2, white — to the terminal 1;
- select D18 sensor type from the thermostat function menu (see Table 1 of the «Sensor Type» Menu).

The supply voltage (230 V ±10 %, 50 Hz) is supplied to terminals 3 and 4, and the phase (L) is determined by the indicator and is connected to terminal 4, and a zero (N) — to the terminal 3.

The connecting wires are connected to the load terminal 5 and the zero terminal block (not included to the set).

DO NOT PERFORM the load connection to the network zero at terminal 3!

**INSTALLATION**

The thermostat is designed for indoor installation. The ingress risk of moisture or liquid into the place of installation must be minimized.

If thermostat is installed in a humid room, it should be placed in enclosure with a protection degree not lower than IP55 in accordance with GOST 14254.

The ambient temperature during installation must be between -5 ...+ 45 °C. The installation height of the thermostat should be in the range 0,5...1,7 m above the floor level.

The temperature controller should be mounted in a special cabinet, which allows accessible installation and operation. The cabinet must be equipped with a standard 35 mm mounting rail (DIN-rail). The temperature controller has width of three standard 18 mm modules.

The thermostat is mounted and connected after the installation and load testing.

In order to protect from short circuits and excess power events appearance in the load circuit, it is necessary to install an automatic circuit breaker (CB), which should be installed in the live wire break, as shown in Wiring 1.

In order to protect a person from electric shock, a residual current device (RCD) should be installed. The load should be grounded (connected to the protective conductor) for proper operation of the RCD or, if the power supply is twowire, a protective grounding (i.e. load to neutral to the RCD) should be made.

The terminals of the temperature controller are designed for a wire with a cross section not exceeding 16 mm<sup>2</sup>. It is desirable to use a soft copper wire to reduce the mechanical loads on the terminals. The use of aluminum is not desirable. Strip the ends of wires 10 ± 0,5 mm. If the striped end is longer, it may cause a short circuit and, if shorter, can cause an unreliable connection. Use cable lugs. Loosen the terminal screws and insert the stripped

end of the wire into the terminal. Tighten the power terminal with moment of 2.4 N·m and sensor terminal — 0,5 N·m. Poor tightening can lead to poor contact and overheating of terminals and wires, and excessive tightening — to damage of terminals and wires. The wires are tightened in the power terminals with a screwdriver with a bit width of not more than 6 mm, and in the terminals for the sensor — of not more than 3 mm. A screwdriver with a bit width of more than 6 mm for power terminals (more than 3 mm for sensor terminals) can cause mechanical damage to the terminals. This may cause to the loss of the warranty.

It is necessary for the temperature controller to switch the current to no more than 2/3 of the maximum current specified in the specification. If the current exceeds this value, the load must be connected through a contactor (magnetic actuator, power relay), which is optimized for this current (Wiring 2).

**Mounting the sensor**

Air temperature sensor should be mounted on the wall or under the edge of the roof in order to ensure its protection from direct sunlight, rain and snow, and ensure the opportunity for easy replacement in the event of a malfunction or damage (Fig. 1).

If necessary, it is allowed to shorten and expand sensor connecting wires (separate cable not more than 40 m long with a cross-section greater than 0,75 mm<sup>2</sup>). Power wires should not be placed near connection wire of sensor otherwise they may cause interference.

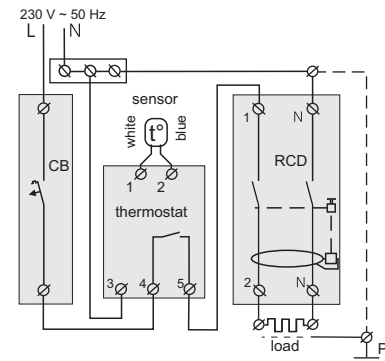

Wiring 1. Circuit breaker and RCD wiring

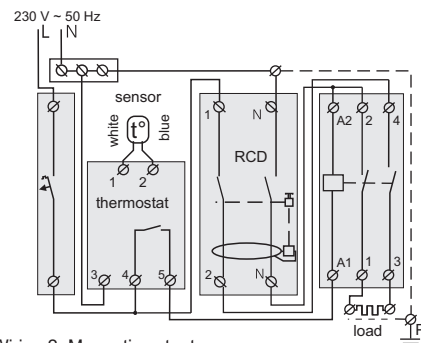

Wiring 2. Magnetic actuator

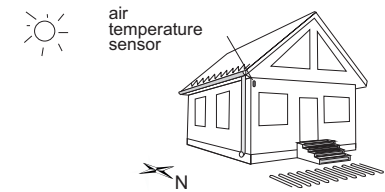

Figure 1. Mounting the air temperature sensor

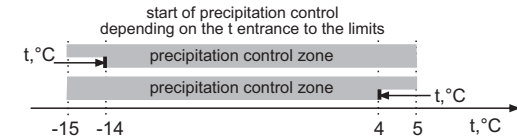

Figure 2. Standard limits with 1 °C hysteresis.

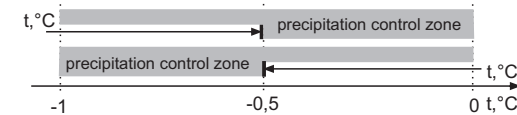

Figure 3. Minimum limits with hysteresis > 1 °C.

**WARRANTY TERMS**

The warranty for **terneo** devices is valid for **36 months** from the date of sale, provided that the instructions are followed. The warranty period for products without a warranty certificate is counted from the date of production.

If your device is not working properly, we recommend that you first read the section «Possible problems». If you cannot find an answer, contact Service Center. In most cases, these actions resolve all issues.

If you continue to have issues with the device, please send it to a Service Center or to the store where you purchased the device. If your device is defective due to our fault, we will repair or replace it under warranty within 14 business days.

Please see the full text of the warranty and the data you need to send to your Service Center on the website <https://www.ds-electronics.com.ua/en/>. If you have a warranty case, please, contact the General distributor in your area.



**SERVICE CENTER CONTACT:**  
+38 (091) 481-91-81  
WhatsApp Viber Telegram  
support@dse.com.ua

**WARRANTY CARD**

serial №:	date of sale:
a seller, a seal:	place of a seal
an owner contact for a service center:	

## EXPLOITATION

### Switching on thermostat



To turn on the thermostat, apply voltage to terminals 3 and 4. The display will show «888» for 3 seconds.

Then the sensor temperature will be displayed.

### Preset temperature

(factory setting upper limit 5 °C, lower -15 °C)

To view the upper temperature threshold, press the «+» button or «-» button to view lower temperature threshold. Flashing value can be changed by means of «+» or «-» buttons. If sensor temperature is within the specified limits, the heater will turn on and the red indicator will switch on.

### Function menu

Use the «≡» button to select the desired menu item (Table 1). Use «+» or «-» to change parameters. After the first press, the parameter starts blinking. At the next press, the parameter is changed.

5 seconds after the last pressing, the thermostat will automatically return to the air temperature display.

### Reset to the factory settings

To reset the factory settings, hold the three buttons at the same time for more than 12 sec until «dEF» message

Table 1. FUNCTION MENU

Menu section	Press button «≡»	Screen	Notes
<b>Manual heating</b> (factory setting «hoF»)	1 time	 	It is used for manual actuation of heater or checking heating system during commissioning. Upon heating mode, use buttons «+» and «-» to change the heating time (by default 3 hours) within the range from 0,5 to 9 hours with an increment of 0,5 hours. Upon operation, the screen will display the remaining time until the heater turns off with an alternating inscription «hon» every 10 seconds.
<b>Load work time counter</b> (view)	2 times		Time output (hours.minutes) is carried out with using creeping line. Press «+» or «-» to view. During reviewing: «-» — is counter reset.
<b>Correction of screen reading</b> (factory setting 0, range ±5 °C, step 0,1 °C)	3 times		If necessary, use the temperature correction on the thermostat screen.
<b>Hysteresis</b> (factory setting «1.0», range 0,1..10 °C, step — 0,1 °C)	4 times		This is the difference between the temperature of the load turn on and off. The lower value of hysteresis allows you to maintain the temperature more accurately, upper - to save on energy consumption and increase the service life of the relay by reducing the number of load switches (see Fig. 2-3).
<b>Sensor type</b> (factory setting «10r»)	5 times		Select the type of sensor you want to use: analog: 4.7r, 6.8r, 10r, 12r, 15r, 33r, 47r, where r — is kOhm at 25 °C, digital: d18.
<b>Switching on / off the load</b> (factory setting «on»)	4 sec	 	To turn off the load, hold 4 with the «≡» button (the screen shows 3 draws) until «oFF» appears on the screen. Turn off the automatic switch completely.  To turn on, also hold the 4 button until «on» appears on the screen.

appears on the screen. After release it will reset to the factory settings and reboot.

### View firmware version

Hold down the «≡» button for 6 seconds. The manufacturer reserves the right to modify the firmware to enhance the device technical characteristics.

## POSSIBLE PROBLEMS, CAUSES AND WAYS TO OVERCOME THEM

### When indicator is not lit by turning on the thermostat at all positions of the regulating knob.

*Possible cause:* no power.

*It is necessary:* to make sure there is power supply voltage with a voltmeter. If there is voltage, then please contact the Service center.

### Load does not work according to settings, every 5 seconds screen displays «OS» or «SC»



open circuit — sensor circuit break



short circuit — short circuit of the sensor circuit

The thermostat switched to the Emergency Timer mode.

*Possible cause:* sensor disconnection, an open circuit in the sensor circuit or the temperature has gone beyond the measured temperatures.

*It is necessary:* check the conformity of the sensor connection, check the connection point of the sensor to the thermostat, as well as the absence of mechanical damage along the entire length of the sensor connecting wire. Absence of a source of electromagnetic field near the sensor wire.

*Work of Emergency operation mode by timer.* This mode ensures the operation of the load in case of sensor damage: in the 30 minute cyclic interval it turns on the load for a set time, and the rest of the time the load is turned off. The operating time of the load can be set in the range of 1 to 29 minutes using the «+» or «-» buttons. Then the screen will display «t» and the time remaining until the next on / off. To make the load work constantly, select «on», to turn off — «oFF». At the first start the Mode value is «oFF».

### The load does not work, the «oht» flashes on the screen



The temperature inside the housing exceeded 80 °C, the protection against internal overheating worked.

*Possible cause:* internal overheating of the thermostat, which can be caused by: poor contact in the terminals of the thermostat, high ambient temperature, exceeding the power of the switching load, or the cross section of the wires for connection is incorrectly selected.

*It is necessary:* to check the tightening of power wires in the terminals of the thermostat, make sure that the switching load power does not exceed the permissible one, the cross section of the wires for connection are selected correctly.

*Features of the protection against internal overheating:* when the temperature inside the housing drops below 60 °C, the thermostat will resume operation. When the protection is triggered more than 5 times in a row, the thermostat will be blocked until the temperature inside the housing drops below 60 °C and one of the buttons is pressed.

### Every 5 seconds the screen displays «Ert»



*Possible cause:* is a break or short circuit of the internal overheating sensor. Internal overheating is not monitored.

*It is necessary:* to send the thermostat to the service center. Otherwise, overheating control will not be carried out.

## ADDITIONAL INFORMATION

Do not fire and do not throw away the device with the household waste.

After the end of its service life, the product must be disposed of in accordance with applicable law.

Transportation of goods carried in the package, ensuring the safety of the product.

The device is transported by any kind of transport (rail, sea,

motor, air transportation).

Date of manufacture is on the back side of device. Application time is unlimited.

The device does not contain harmful substances.

If you have any questions or you something will not clear, call the Service centre the telephone number listed below.

## SAFETY INSTRUCTIONS

Carefully read and become aware of yourself these instructions.

Connection of the device must be done by a qualified electrician.

Do not connect 230 V mains voltage instead of the sensor (it leads to failure of the thermostat).

Before the installation (dismantling) and connection (disconnection) of the device, turn off voltage supply and also act according to the «Rules of an arrangement of electric installations».

Do not immerse the sensor with a connecting wire in the liquid medium.

Do not switch the non assembled device to the network.

Turning on and off or and configure the device should be with dry hands.

Do not connect the device to the network disassembled.

Avoid hitting of water or moisture to the device.

Do not expose the device to extreme temperatures (higher than 40 °C or below -5 °C) and high humidity.

Never clean the device with the use of chemicals such as benzene, solvents.

Do not store the device and do not use it in areas with the dust.

Do not attempt to disassemble and repair the device.

Do not exceed the landmarks value adaptor and power.

To protect against overvoltage caused by lightning discharges, use a lightning protector.

Protect the children from games with the working device, it is dangerous.

v30\_220906



Low Voltage Directive 2014/35/EU  
EMC Directive 2014/30/EU

Manufacturer and vendor: DS ELECTRONICS, LTD  
04136, Ukraine, Kyiv region, Kyiv, 1-3 Pivnichno-Syretska str.  
+38 (091) 481-91-81, Service Center: +38 (091) 481-91-81  
support@dse.com.ua www.ds-electronics.com.ua/en/