

Thermostat terneo rk is designed for constant temperature maintenance $-55...125\text{ }^{\circ}\text{C}$. With a wide range of temperatures and adjustable hysteresis, the thermostat can be used to maintain a constant temperature in the piping system, ensure stable operation of a high-power electric boiler, upgrade an old electric boiler, heat the sewage system or greenhouse.

According to the data from the temperature sensor, the thermostat controls heating: turns off heating when the desired temperature is reached and turns on when it decreases by the hysteresis value.

IN THE BOX

Thermostat	1 piece
Temperature sensor with connected sensor	1 piece
Technical data sheet and installation and operation manual and warranty card	1 piece
The packing box	1 piece

TECHNICAL DATA

Adjustment range	$-55...125\text{ }^{\circ}\text{C}$
Maximum load current (for category AC-1)	32 A (max 40 A in 10 minutes)
Rated load capacity (for category AC-1)	7 000 VA
Input voltage	230 V $\pm 10\%$
Power consumption	not more than 1,5 kWt*h / month
Weight in the complete set	0,26 kg $\pm 10\%$
Basic mounting dimensions	70 × 85 × 53 mm
Temperature sensor	DS18B20 (D18)
The length of the sensor connected cable	4 m
Number combinations under heat, at least	100 000 cycles
Number of combinations without heating, no less than	1 000 000 cycles
Temperature hysteresis	0,5–25 $^{\circ}\text{C}$
Degree of protection GOST14254	IP20

IMPORTANT. Before the installation and operation of the device, please read by the end of this document. This will help to avoid possible danger, mistakes and misunderstandings.

WIRING

Digital sensor (D18) is connected to terminal 1 using white wire and to terminal 2 using blue (yellow) wire. If the thermostat changes to the Emergency Timer mode, try connecting to terminal 2 using blue wire and to terminal 1 using white wire. If, at both attempts, the thermostat does not see the sensor, contact the Service Center.

Power voltage (230 V $\pm 10\%$, 50 Hz) is supplied to terminals 3 and 4, at that phase (L) is determined by indicator and is connected to terminal 4, and neutral (N) — to terminal 3.

The load interconnecting wires are connected to terminal 5 and to the zero terminal block (not included in the package).

The thermostat supports operation with an analog sensor NTC R10 10 kOhm at 25 $^{\circ}\text{C}$ (R10) in the temperature range $-30... + 85\text{ }^{\circ}\text{C}$. The wire colors for the analog sensor are irrelevant when connected.

DO NOT PERFORM the load connection to the network zero at terminal 3!

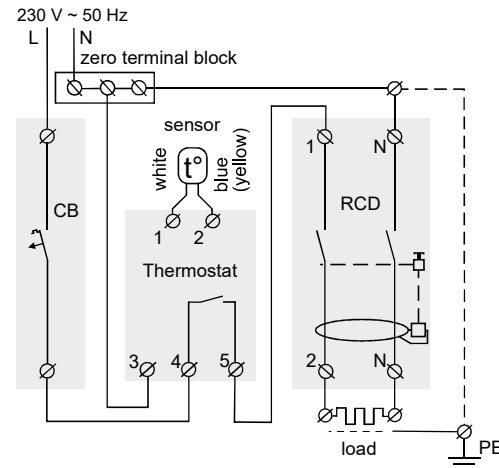

Wiring 1. Circuit breaker and RCD wiring

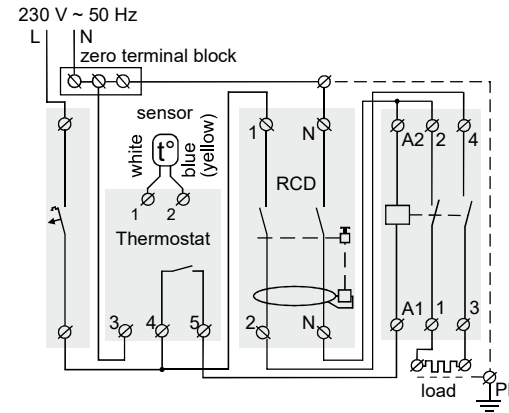

Wiring 2. Magnetic actuator

INSTALLATION

The thermostat is designed for indoor installation. The ingress risk of moisture or liquid into the place of installation must be minimized. The ambient temperature during installation must be between $-5... + 45\text{ }^{\circ}\text{C}$. The installation height of the thermostat should be in the range 0,4...1,7 m above the floor level.

The temperature controller should be mounted in a special cabinet, which allows accessible installation and operation. The cabinet must be equipped with a standard 35 mm mounting rail (DIN-rail). The temperature controller has width of three standard 18 mm modules.

The thermostat is mounted and connected after the installation and load testing.

In order to protect from short circuits and excess power events appearance in the load circuit, it is necessary to install an automatic circuit breaker (CB), which should be installed in the live wire break, as shown on Wiring 1.

In order to protect a person from electric shock, a residual current device (RCD) should be installed. The load should be grounded (connected to the protective conductor) for proper operation of the RCD or, if the power supply is twowire, a protective grounding (i.e. load to neutral to the RCD) should be made.

To install the temperature controller you should:
— fix the temperature controller on the mounting rail (DIN);
— supply power, load and sensor wires;
— make a connection according to this manual.

The terminals of the temperature controller are designed for a wire with a cross section not exceeding 16 mm². It is desirable to use a soft copper wire to reduce the mechanical loads on the terminals. The use of aluminum is not desirable. Strip the ends of wires 10 \pm 0,5 mm. If the stripped end is longer, it may cause

a short circuit and, if shorter, can cause an unreliable connection. Use cable lugs. Loosen the terminal screws and insert the stripped end of the wire into the terminal. Tighten the power terminal with moment of 2,4 N·m and sensor terminal — 0,5 N·m. Poor tightening can lead to poor contact and overheating of terminals and wires, and excessive tightening — to damage of terminals and wires. The wires are tightened in the power terminals with a screwdriver with a bit width of not more than 6 mm, and in the terminals for the sensor — of not more than 3 mm. A screwdriver with a bit width of more than 6 mm for power terminals (more than 3 mm for sensor terminals) can cause mechanical damage to the terminals. This may cause to the loss of the warranty.

If necessary the sensor connecting wires may be shortened and extended (for not more than 20 m).

It is necessary for the temperature controller to switch the current to no more than 2/3 of the maximum current specified in the specification. If the current exceeds this value, the load must be connected through a contactor (magnetic actuator, power relay), which is optimized for this current (Wiring 2).

WARRANTY TERMS

The warranty for **terneo** devices is valid for **36 months** from the date of sale, provided that the instructions are followed. The warranty period for products without a warranty certificate is counted from the date of production.

If your device is not working properly, we recommend that you first read the section «Possible problems». If you cannot find an answer, contact Service Center. In most cases, these actions resolve all issues.

If you continue to have issues with the device, please send it to a Service Center or to the store where you purchased the device. If your device is defective due to our fault, we will repair or replace it under warranty within 14 business days.

Please see the full text of the warranty and the data you need to send to your Service Center on the website <https://www.ds-electronics.com.ua/en/>. If you have a warranty case, please, contact the General distributor in your area.

WARRANTY CARD

serial №:	date of sale:
a seller, a seal:	place of a seal
an owner contact for a service center:	

EXPLOITATION

Use the «**≡**» button to select the desired menu item. Use «**+**» or «**-**» to change the parameters. The first press causes a flashing of the parameter, the next one — a change. Temperature display returns after 5 seconds after the last pressing the buttons.

Switching on thermostat



To turn on the thermostat, apply voltage to terminals 3 and 4. The display will show «**888**» for 3 seconds.

Then the sensor temperature will be displayed.

Preset temperature (factory setting 25 °C)

To view, click on the «**+**» or «**-**». The next press on «**+**» will increase the preset temperature, on «**-**» it will decrease. If the preset temperature is lower than the sensor temperature, the heater will turn on and the red indicator will light up.

Example. It is necessary that the heater maintains a room temperature of 25...27 °C. We set: preset temperature (t_{preset}) — 27 °C, hysteresis — 2 °C. The power will turn off at 27 °C and turn on at 25 °C.

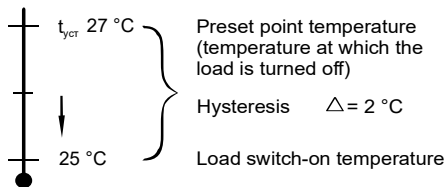

Table 1. FUNCTION MENU

Menu section	Press « ≡ »	Screen	Notes
Hysteresis (factory setting «1.0», range 0,5...25 °C, step 0,5 °C)	1 time		This is the difference between the temperature of the load turn on and off. The lower value of hysteresis allows you to maintain the temperature more accurately, upper — to save on energy consumption and increase the service life of the relay by reducing the number of load switches.
Delay timer on / OFF (factory setting «toF»)	2 times	 	To start the timer, select « ton ». Screen will display the time until operation is resumed with a flashing « h » (for example: 9.0h). « ton » — timer on, « toF » — timer oFF.
Delay timer setting (factory setting 9 h, range 0,5–99 h)	3 times		Select the time after which the heating will resume.
Correction of screen reading (factory setting 0, range ±5 °C, step 0,1 °C)	4 times		If necessary you can use the adjustment in the floor temperature display on the thermostat screen.
Inverse load control (factory setting «oFF»)	5 times		Select « on » in the settings menu to switch to normally closed contact mode. Activate the function, for example, when connecting a normally open servo.
Load run time counter (view)	6 times		Time output (hours.minutes) is carried out with using creeping line. Press « + » or « - » to view. During reviewing: « - » — is counter reset.

Resetting to factory settings

To reset, hold down three buttons and hold for more than 12 seconds. «**dEF**» inscription will appear on the screen. After releasing the buttons, the screen blinks off and the thermostat restarts.

Firmware version view

Holding the «**-**» button for more than 6 seconds will display the firmware version on the screen. After releasing the button, the thermostat returns to the normal operation mode.

POSSIBLE PROBLEMS, CAUSES AND WAYS TO OVERCOME THEM

Load is off, screen and indicator are off

Possible cause: No power supply.

It is necessary: make sure that the supply voltage is available. If power supply is available, contact the Service Center.

The load does not operate according to the settings, every 5 seconds the screen displays «OC» or «SC»



open circuit — sensor circuit break



short circuit — short circuit of the sensor circuit

The thermostat has switched to the Emergency Timer Mode.

Possible reason: failed connection, damage to the sensor circuit or temperature exceeds the limits of the measured temperatures (Technical data table).

Required: check the junction of the temperature sensor with the thermostat and its circuit, check for mechanical damages along the entire length of the connecting wire and no power wiring that passes close.

Timer-based emergency operation mode (factory setting 15 min.) This mode ensures the operation of the thermostat in case of damage to the sensor: in a 30-minute cyclic interval it turns on the load for the set time, the rest of the time the load is turned off. The load operating time is adjustable from 1 to 29 minutes using the «**+**» or «**-**» buttons. To ensure continuous operation of the load, select «**on**» and to turn the load completely off, select «**oFF**».

The load is disabled, «ohT» flashes on the screen



The temperature inside the housing exceeded 80 °C, the protection against internal overheating worked.

Possible cause: internal overheating of the thermostat, which can be caused by: poor contact in the terminals of the thermostat, high ambient temperature, exceeding the power of the switching load, or the cross section of the wires for connection is incorrectly selected.

It is necessary: to check the tightening of power wires in the terminals of the thermostat, make sure that the switching load power does not exceed the permissible one, the cross section of the wires for connection are selected correctly.

Features of the protection against internal overheating: when the temperature inside the housing drops below 60 °C, the thermostat will resume operation. When the protection is triggered more than 5 times in a row, the thermostat will be blocked until the temperature inside the housing drops below 60 °C and one of the buttons is pressed.

Every 5 seconds the screen displays «Ert»



Possible cause: is a break or short circuit of the internal overheating sensor. Internal overheating is not monitored.

It is necessary: to send the thermostat to the service center. Otherwise, overheating control will not be carried out.

ADDITIONAL INFORMATION

Do not fire and do not throw away the device with the household waste.

After the end of its service life, the product must be disposed of in accordance with applicable law.

Transportation of goods carried in the package, ensuring the safety of the product.

The device is transported by any kind of transport (rail, sea, motor, air transportation).

Date of manufacture is on the back side of device. Application time is unlimited.

The device does not contain harmful substances.

If you have any questions or you something will not clear, call the Service centre the telephone number listed below.

SAFETY INSTRUCTIONS

Carefully read and become aware of yourself these instructions.

Connection of the device must be done by a qualified electrician.

Do not connect 230 V mains voltage instead of the sensor (it leads to failure of the thermostat).

Before the installation (dismantling) and connection (disconnection) of the device, turn off voltage supply and also act according to the «Rules of an arrangement of electric installations».

Do not immerse the sensor with a connecting wire in the liquid medium.

Do not switch the non assembled device to the network.

Turning on and off or and configure the device should be with dry hands.

Do not connect the device to the network disassembled.

Avoid hitting of water or moisture to the device.

Do not expose the device to extreme temperatures (higher than 40 °C or below -5 °C) and high humidity.

Never clean the device with the use of chemicals such as benzene, solvents.

Do not store the device and do not use it in areas with the dust.

Do not attempt to disassemble and repair the device.

Do not exceed the landmarks value adaptor and power.

To protect against overvoltage caused by lightning discharges, use a lightning protector.

Protect the children from games with the working device, it is dangerous.

v13_220613



Low Voltage Directive 2014/35/EU
EMC Directive 2014/30/EU

Manufacturer and vendor: DS ELECTRONICS, LTD
 04136, Ukraine, Kyiv region, Kyiv, 1–3 Pivnichno-Syretska str.
 +38 (091) 481-91-81, Service Center: +38 (091) 481-91-81
 support@dse.com.ua www.ds-electronics.com.ua/en/