

# CABINETS FOR DRYING

OF WORKING AND PROTECTIVE CLOTHING - type SSO



## **CABINETS FOR DRYING AND VENTILATING OF WORKING AND PROTECTIVE CLOTHING**

INSTANT DRYING !

DUMP AND WET CLOTHES !

DETAILS AND MATERIALS ARISING FROM TECHNOLOGICAL WORKS !

### **APPLICATIONS**

- A. Industry and services
- B. Technological works
- C. Food and agricultural output
- D. Recreational facilities for winter sports

Cabinet necessary in equipment units that are working whatever the season and weather conditions

**COMFORT, NEATNESS and CLEANLINESS !**

## **DRYING CABINET type SSO**

IZOTERMA PRODUKT

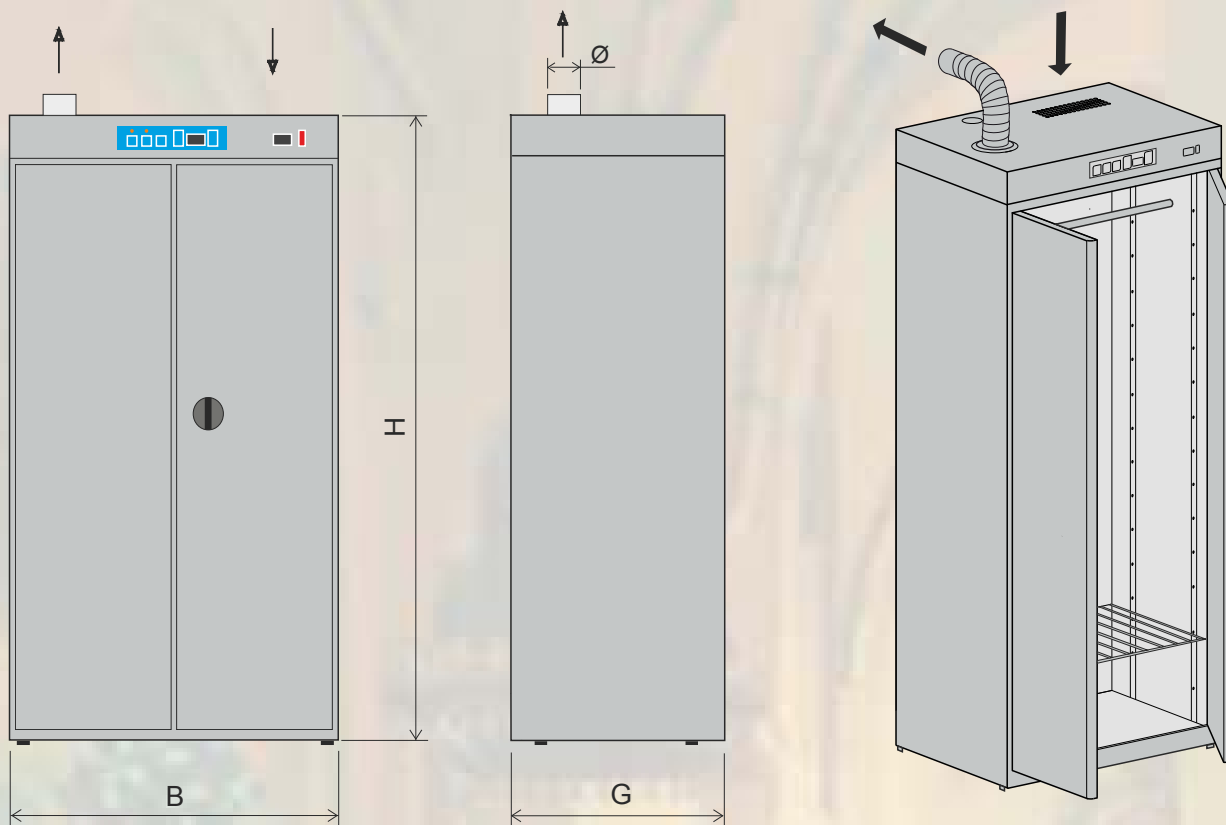

#### DATA OF CABINS MANUFACTURED BY ZPUG IZOTERMA

No.	Type 230V, 50 Hz	Dimensions - mm				Power kW	Fan		Static press. Pa	V - m <sup>3</sup> chamber	Amount of doors	Weight kg	sets of clothes*
		B	G	H	Ø		Power - W	m <sup>3</sup> /h					
1.	<b>SSO-1M</b>	800	500	1825	100	2,0	46	240	64	0,72	2	61	8
2.	<b>SSO- 60</b>	600	600	1825	100	1,5	46	240	64	0,65	1	57	6
3.	<b>SSO- 80</b>	800	600	1825	100	2,0	46	240	64	0,86	2	66	8
4.	<b>SSO-100</b>	1000	600	1825	100	2,0	46	240	64	1,10	2	76	10

\* – assumed average thickness of male jacket

**INSTALLATION** – set the cabinet on an even surface, check the level on the ground, mount the spiro-pipe into the ventilation grille and then connect the cabinet to a 230V socket.

**DESIGN** – cabinet design – self-supporting, made of sheet steel, galvanized; painted, welded or made of stainless steel; two-leaf doors with a lock. Internal equipment of the cabinet – made of steel.

**DRYING PROCESS** – heating and ventilation unit and controller is located at the top of the ceiling of the cabinet – this protects against accidental damage and is also safe for the user of the cabinet.

After switching the cabinet on, air is drawn through the turbine-fan from the immediate surrounding through openings in the cover of the ceiling and then pushed into an electric heater. The heated air is directed – with high speed – down towards the floor, and then reflected back from the floor – it is directed upwards. This drying process works on the charge which is to be dried not only from the top, but also from the bottom; turbulent air flow penetrates every possible nook and cranny of the charge which is to get dried.

At the same time, separation of the air occurs in the cabinet. A portion of the air is directed outwards, drawing out moisture from the cabinet to the ventilation duct – and the remaining part of the air is re-introduced into circulation. The turbulent air flow in the cabinet causes that the drying process is precise and relatively short (therefore economical).

#### IZOTERMA - BZ 2

Electronic intuitive controller for programming of: time, temperature; humidity indicator



**CERTIFICATE** – CE B TÜV Hygienic Certificate, Declaration of Conformity.

**STORAGE AND TRANSPORT** – The cabinet must be transported in an upright position – (working position) on Euro pallet, without high-stacking of cabinets. It should be noted that both the transport and storage of the product is to be performed in a safe manner, and the area of storage should not be moist, without the possibility of mechanical damage (during placement, uncontrolled movement, shock, tipping over, etc.). Apart from these, there are no specific recommendations regarding safe storage and transport. We reserve the right to change the design of the product.

We reserve the right to change products construction